



AUTHOR  
Isaac Frampton  
Senior Staff Engineer

# Identifying Load Management System Applications; Part 1 of 3

## INTRODUCTION

Load-management systems can improve flexibility, versatility and power quality of a power generation system. This three-part series explores tips for setting up load-management systems along with guidelines for seven load-management methods. This first installment focuses on appropriate applications of load-management systems where controlling load priorities can improve power quality to critical loads.

## WHAT IS LOAD MANAGEMENT

A load-management system allows industrial management and facilities engineers to control when a load is added or shed from a power system, making paralleling systems more robust and improving power quality to critical loads on many power generation systems.

In the simplest form, load management, also called load add/shed or load control, allows removal of noncritical loads when the capacity of the power supply is reduced or unable to support the entire load. If the noncritical loads are removed, critical loads can retain power under circumstances where they could otherwise experience poor power quality due to an overload condition or lose power due to a protective shutdown of the power source. It allows for removal of noncritical loads from the power generation system based on certain conditions such as a generator overload scenario. Load management enables loads to be prioritized and removed or added, based on certain conditions such as generator load, output voltage or AC frequency. On a multi-generator system, if one generator shuts down or is unavailable, load-management enables lower priority loads to be disconnected from the bus. This ensures that the critical loads are still operational even with a system that has an overall capacity lower than originally planned. In addition, by controlling how many and which noncritical loads are shed, load management can enable a maximum number of noncritical loads to be supplied with power based on the actual system capacity.

In many systems, load management can also improve power quality. For example, in systems with large motors, the starting of the motors can be staggered to allow a stable system as each motor starts. Load management can further be utilized to control a load bank so when loads are below a desired limit, the load bank can be activated, ensuring proper operation of the generator.

Load management may also provide load relief so that a single generator can connect to the bus without being overloaded immediately. Loads can be added gradually, with a time delay between adding each load priority, enabling the generator to recover voltage and frequency between steps.

## WHEN TO USE LOAD MANAGEMENT

There are many instances where load management can improve the reliability of a power generation system. A few applications where the use of load management may be implemented are highlighted below.

- Standard paralleling systems
- Dead-field paralleling system
- Single-generator systems
- Systems with special emissions requirements

### STANDARD PARALLELING SYSTEMS

Most standard paralleling systems have use for some type of load management because the load must be energized by a single generator before the others can synchronize to it and add power generation capacity. Further, that single generator may not be able to supply the power requirements of the entire load.

Standard paralleling systems will start all generators simultaneously, but they are unable to synchronize to each other without one of them energizing the paralleling bus. One generator is chosen to energize the bus so that the others can synchronize to it.

Although most generators are typically synchronized and connected to the paralleling bus within a few seconds of the first generator closing, it is not uncommon for the synchronization process to take up to a minute, long enough for an overload to cause the generator to shut down to protect itself.

In addition, it can be difficult for generators to synchronize to an overloaded bus due to abnormal voltage and frequency levels or frequency and voltage fluctuations, so the incorporation of load-management can help bring additional generators online more quickly. A properly configured load management system will typically provide good power quality to critical loads during the synchronization process by ensuring that the online generators are not overloaded, even if the synchronizing process takes longer than expected.

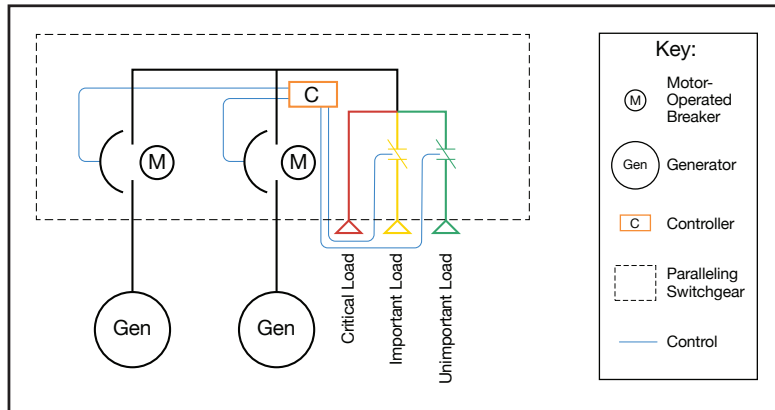

Figure 1: Parallel Generators with Load Management in Switchgear

## STANDARD PARALLELING SYSTEMS (CONTD)

Load management may be implemented in a multitude of ways. Standard paralleling systems are often controlled by paralleling switchgear as shown in Figure 1. The paralleling switchgear typically contains a programmable logic control (PLC) or other logic device that controls the sequence of operation of the system. The logic device in the paralleling switchgear can also perform the load management.

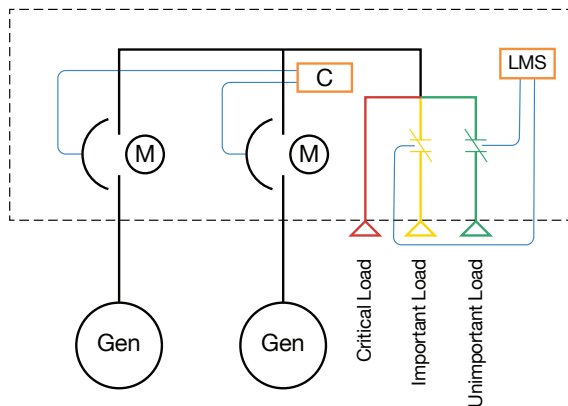

Figure 2: Parallel Generators with Load Management System (LMS)

Load management may be performed by a separate load-management system (Figure 2), which may provide metering or may use information from the paralleling switchgear controls to determine generator loading and frequency.

A building-management system may also perform load management, controlling the loads by supervisory control and eliminating the need for switches to interrupt the power to them Figure 3.

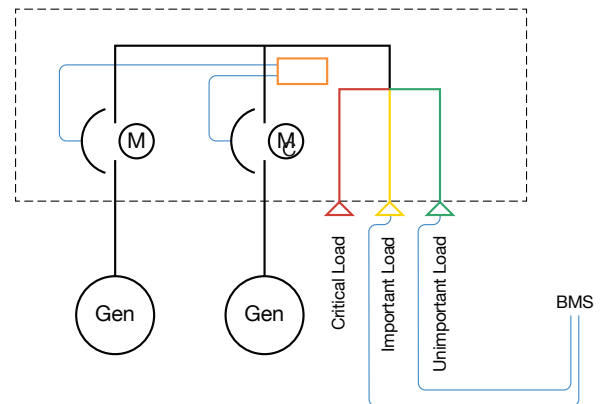

Figure 3: Parallel Generators with Load Management System (LMS)

## DEAD-FIELD PARALLELING SYSTEMS

Dead-field paralleling differs from standard paralleling in that all generators can be paralleled before their voltage regulators are activated and the alternator fields are excited. If all generators in a dead-field paralleling system start normally, the power system reaches rated voltage and frequency with full-power generation capacity available to supply the load..

Because the normal dead-field paralleling sequence does not require a single generator to energize the paralleling bus, load management should not need to shed load during a normal system start. However, as with standard paralleling systems, the starting and stopping of individual generators is possible with dead-field paralleling. If a generator is down for service or stops for another reason, the other generators may still be overloaded. Thus, load management may still be useful in these applications, similar to standard paralleling systems.

## DEAD-FIELD PARALLELING SYSTEMS (CONTD)

Dead-field paralleling is usually performed by parallel-capable generator controllers as shown in *Figure 4*, but it can also be performed by a paralleling switchgear installation. Parallel-capable generator controllers often provide built-in load management, allowing the load priorities to be directly managed by the controllers and eliminating the need for paralleling switchgear controllers.

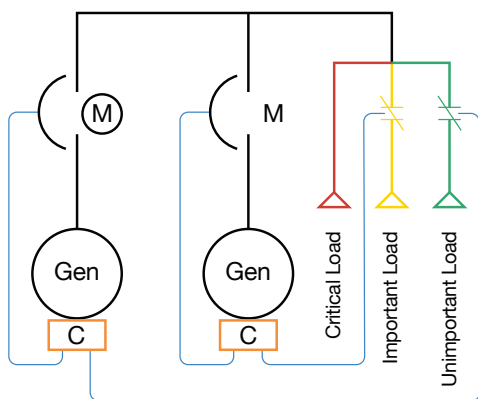

*Figure 4: Parallel Generators with Load Management in Controller*

## SINGLE-GENERATOR SYSTEMS

Single-generator systems are typically less complicated than their paralleling counterparts. Such systems may use load management in the generator controller to control loads when subject to intermittent loads or load variations. *Figure 5* shows a single generator system using automatic transfer switches to interrupt loads.

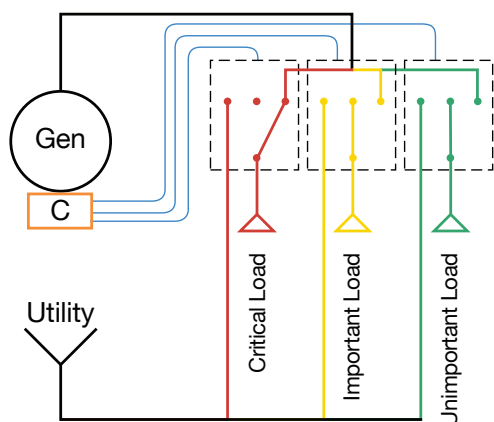

*Figure 5: Single-Generator Controlling ATS*

An intermittent load—such as chillers, induction ovens and elevators—does not draw continuous power, but it can vary power requirements suddenly and significantly. Load management can be useful in situations where the generator is capable of handling a normal load, but under certain circumstances intermittent loads may increase the total load of the system above the maximum power capability of the generator, potentially hurting the power quality of the generator output or inducing a protective shutdown.

Load management can also be used to stagger application of loads to the generator, minimizing the voltage and frequency variation caused by the inrush to large motor loads. Load management may also be useful if local codes require a load control module for systems where the rated generator output current is less than the service entrance current rating.

## SYSTEMS WITH SPECIAL EMISSIONS REQUIREMENTS

In some geographic areas, there are minimum load requirements for a generator anytime it is operating. In this case, load management could be used to keep loads on the generator to help meet emissions requirements.

For this application, the power generation system is fitted with a controllable load bank. The load-management system is configured to energize various loads in the load bank to maintain the generator system output power above a threshold *Figure 6*.

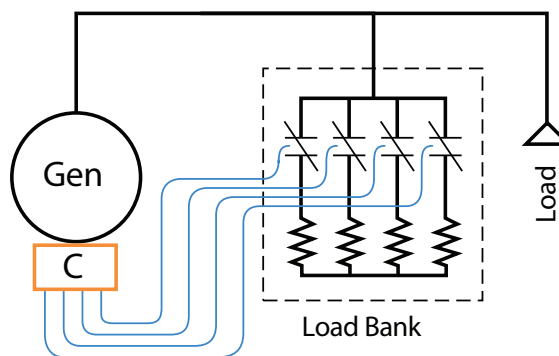

*Figure 6: Single-Generator with Special Emission Requirements*

---

## **SYSTEMS WITH SPECIAL EMISSIONS REQUIREMENTS (CONTD)**

Certain generator systems include a Diesel Particulate Filter (DPF), which typically needs to be regenerated. In some cases, engines will derate to 50 percent of rated power during a parked regeneration of the DPF, and could leverage the load-management system to remove some loads during that condition.

## **WHEN LOAD MANAGEMENT MAY NOT BE NECESSARY**

Although load management can improve power quality to critical loads in any system, it may add delays before some loads receive power, increase the complexity of the installation and add a significant amount of wiring effort as well as parts cost, such as contactors or circuit breakers. Some applications where load management may be unnecessary are outlined below.

### **PROPERLY SIZED SINGLE GENERATOR**

There is usually no need for a load-management system on a properly sized single generator, as an overload condition is unlikely, and generator shutdown will result in all loads losing power, regardless of priority.

### **PARALLELING GENERATORS FOR REDUNDANCY**

Load management is generally unnecessary in situations where there are paralleling generators and the site power requirements can be supported by any one of the generators, as a generator failure will only result in another generator starting, with only a temporary interruption in the load.

## **ALL LOADS ARE EQUALLY CRITICAL**

On sites where all loads are equally critical, it is difficult to prioritize the loads, shedding some critical loads in order to continue providing power to other critical loads. In this application, the generator (or each generator in a redundant system) should be appropriately sized to support the entire critical load.

*The next installment of this three-part series will explore setting up load-management systems, determining load priority orders and methods of shedding loads.*

---

## ABOUT THE AUTHOR



Isaac Frampton is a Senior Staff Engineer at Rehlko Co. He has worked for the company's Rehlko Power Systems division since 2006 and specializes in control system design and paralleling applications. He has a bachelor of science in electrical engineering from Kettering University in Flint, Michigan.

## ABOUT POWER SYSTEMS

Power Systems, Rehlko's largest division, delivers worldwide energy solutions designed to ensure resilience for mission-critical applications of all sizes. Building on more than a century of expertise and dedication, the company offers complete power systems, including industrial backup generators (HVO, diesel, gaseous), enclosures, hydrogen fuel cells systems, automatic transfer switches, switchgear, monitoring controls, genuine parts and end-to-end services. As a global company with service partners in every country, Power Systems provides reliable, cutting-edge technology to keep industries and businesses running.

[www.powersystems.rehlko.com](http://www.powersystems.rehlko.com)

## ABOUT REHLKO

A global leader in energy resilience, Rehlko delivers innovative energy solutions critical to sustain and improve life across home energy, industrial energy systems, and powertrain technologies, by delivering control, resilience and innovation. Leveraging the strength of its portfolio of businesses – Power Systems, Home Energy, Uninterruptible Power, Clarke Energy, Heila Technologies, Curtis Instruments, and Engines, and more than a century of industry leadership, Rehlko builds resilience where and when the grid cannot, and goes beyond functional, individual recovery to create better lives and communities, and a more durable and reliable energy future.